

Fixture Type:



S6-3055Z
pictured

The SHAKESPEARE Series Zoom ellipsoidals are the state of the art in variable focus theatrical luminaires for function, style, and efficiency. These ellipsoidals have been designed and engineered with a number of innovative details and features enhancing versatility and efficiency without sacrificing performance. The dichroic coated glass reflector removes heat from the beam, resulting in longer gel and pattern life. The super smooth, variable focus lens system, which operates with Teflon bearings on stainless steel guide rails, produces wide-to-narrow beams offering a sharp, full field and distortion free pattern projection. The generous accessory slot, the two-slot accessory holder, and self-closing, self-locking retaining latch for the accessory holder are just some of the special features provided. The aesthetic appearance and ergonomically designed function controls only add to its appeal. With a wide range of non-proprietary lamps to choose from, the low wattage, high output SHAKESPEARE zooms are ideal for theatres, night-clubs, television studios, or wherever superior, energy efficient lighting performance is required.

Specifications subject to change without notice

750 WATT

SHAKESPEARE® Series ZOOM ELLIPSOIDAL

Features

- Compact, rugged die-cast aluminum construction
- Spring mounted dichroic coated glass reflector provided with heat shield
- Lockable, 180° indexed rotation of shutter assembly and lens barrel, optional 360° rotation
- Color Coded lens and lens barrel identification system
- Tempered crown glass lenses have anti-reflective coating
- Zoom focus lens carriers use Teflon glide bearings on stainless steel guide rails
- Tool free operating lamp centering knob and peak to flat field adjustment knob
- Replaceable two-slot accessory holder provided with self-closing and self-locking accessory retaining latch
- Accessory slot provided with locking cover that will accept rotating gobo accessories, glass pattern holder and drop-in-iris
- Removable lens access panel
- Tool free removable heavy gauge stainless steel shutters mounted in separate planes equipped with oversized insulated handles, and spring pressured shutter assembly
- Dual positioning yoke supplied with dual positive locking dogs and tilt angle markings
- Protective insulated rear mounted ring handle serves as a cord wrap, stand, and focusing aid
- G9.5 medium two-pin lampholder provided with heat shield that accepts a wide variety of non-proprietary lamps
- Uses standard 7 1/2" accessories
- Three 36" Teflon lead wires
- Up to 25' of Hi-Temp rubber cable optional
- Color frame and safety cable included
- U.L., c.U.L. and CE listed for 750 watts
- Made in the USA

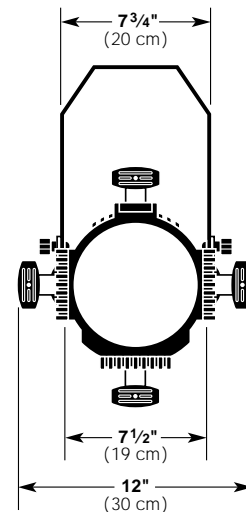
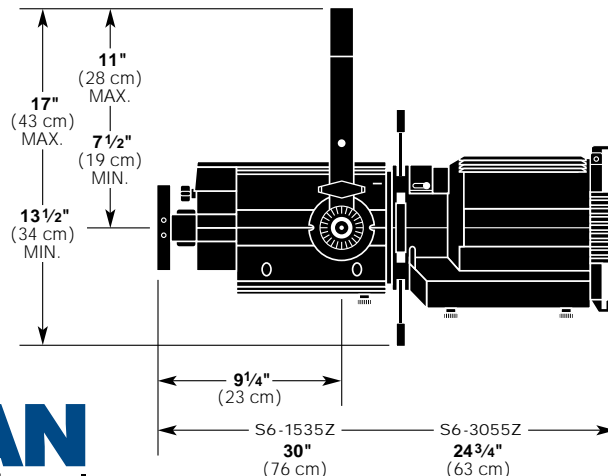

Specifications

Housing: Die-cast aluminum construction.

Materials: Construction employs all corrosion-resistant materials and hardware.

Yoke: Rigid flat steel with dual locking dog tilt handles, two mounting positions, indexed pivot angle markings.

Reflector: Spring mounted dichroic coated glass, elliptical design, provided with heat shield.

Lenses: Color coded crown glass (white plate) lenses provided with anti-reflective coating.

Lens Barrel: Die-cast aluminum construction, color coded and marked, rotates 180° with shutter assembly.

Socket: Altman G9.5 medium two-pin, axially mounted, supplied with heat shield. Tool free relamping.

Rating: 120/240 volts AC/DC operation, 6.3/3.1 amps, 750 watts maximum.

Cable: 36" Teflon leads encased in black fiberglass sleeving, rear cord wrap provided. Hi-Temp rubber cable optional, up to 25'.

Shutters: Four provided, .037" stainless steel, fully adjustable and removable. Constructed with oversized Valox heat resistant handles.

Shutter Assembly: Spring pressured, 180° indexed rotation on Teflon glides, provided with locking knob.

Access Door: Removable, allowing access to lens.

Focusing Lamp: Fully adjustable in three axis with two concentric Ultem 2100 heat resistant knobs.

Focusing Fixture: Zoom lens movement contained within body. Lens carriers travel on Teflon glide bearings along stainless steel guide rails, each lens carrier provided with heat resistant lock knob. Ring shaped rear mounted aiming handle provided, constructed of Ultem 2100.

Accessories: Accessory slot provided with cover, rotates 180° with shutter assembly, accepts drop-in iris and rotating gobo accessories. Removable Lexan front end accessory holder equipped with two slots and accepts standard 7 1/2" accessories. Accessory holder retaining latch is self-closing and self-locking for safety.

Finish: Black epoxy sandtex, electrostatic application.

Weight: Approx; 22 lbs. (9.9 kg.) for S6-1535Z.
Approx; 21 lbs. (9.5 kg.) for S6-3055Z.

ACCESSORIES Supplied with Luminaire	
6-CF	Color Frame, 7 1/2" x 7 1/2"
SC	Safety Cable with Spring Clip

ADDITIONAL ACCESSORIES	
510-HD	Heavy-Duty Malleable Iron Pipe Clamp
6-CFB	Black Color Frame, 7 1/2" x 7 1/2"
360-PH	Pattern Holder with Channels, 2 3/4" diameter opening, 3 3/8" wide
1KL6-PH	Pattern Holder with Slots, 2 3/4" diameter opening, 3 3/8" wide
S6-GPH	Pattern Holder for Glass Patterns
6-SN	Snoot
404.6	Motorized Color Wheel
6-DN	Donut, 7 1/2" x 7 1/2" w/3" diameter opening
SDii	Drop-in iris

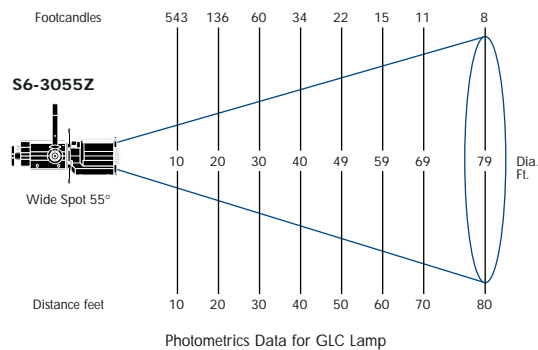
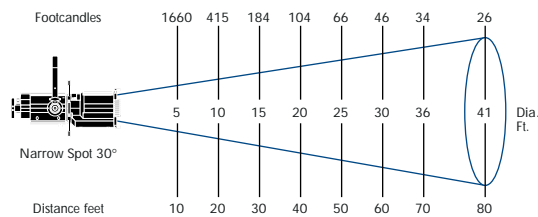
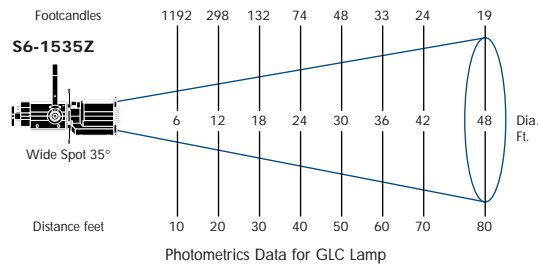
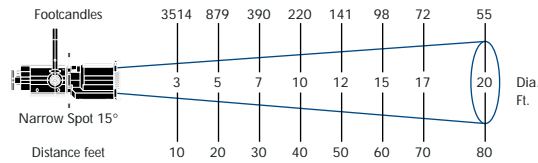

LAMP DATA

Watts	Volts	ANSI Code	Manufacturer Lamp Code	Color Temp (°K)	Rated Life (Hours)	Rated Lumens	Correction Factor
400	115	—	HX400	3200°	300	10,000	.69
400	115	—	HX401	3050°	1500	8,500	.59
575	115	—	HX604	3250°	400	15,500	1.14
575	115	—	HX605	3100°	1500	13,500	.88
600	230	GKV	HX600/HV230	3200°	400	14,500	1.00
575	115	GLC	HP600/6989P	3200°	400	15,500	—
575	115	GLA	HP600/6992P	3100°	1500	13,500	—
750	115	—	HX754	3200°	300	21,500	—
750	115	—	HX755	3050°	1500	18,250	—

SHAKESPEARE PERFORMANCE CHART WITH GLC LAMP

Fixture Type	Candlepower (Candela)	Beam Angle (Degrees)	Field Angle (Degrees)	Efficiency (%)
Narrow Spot				
S6-1535Z	351,000	9°	15°	48
S6-3055Z	166,000	13°	30°	60
Wide Spot				
S6-1535Z	119,000	15°	35°	65
S6-3055Z	55,000	15°	55°	65